



## LGT-T4

### Complete Plug and Play Turn Signal Kit Designed for RHOX Plug & Play Wire Harness Installation Instructions



**Caution:** Please read through the instructions carefully. Before starting this project, remove the system's positive and negative connections from the battery or battery pack. This kit is designed for a 12V operation only. Operating this kit at a higher voltage will void any and all warranties. Look behind each drill location **BEFORE YOU DRILL**. Installer is responsible for damage (i.e. drilling into a wiring harness, battery, fuel tank etc.).

## Table of Contents

- 1) **Universal Turn Signal Installation** ..... Page 2
- 2) **12V Horn Installation** ..... Page 5
- 3) **Dual USB Outlet Installation** ..... Page 5
- 4) **Brake Pad Switch Installation** ..... Page 6

## Tools Needed for Installation

- Screwdriver (Phillips)
- Socket & Ratcheting Wrench (7/16")
- Drill, Drill Bits and Hole Saws (3/16", 1/4", 1-1/8")
- Rivet Gun
- Marking Device

## Before You Start

1. Turn Key OFF.
2. Place Tow/Run Switch in Tow if equipped.
3. Remove the system's positive and negative connections from the battery or battery pack.
4. Engage the parking brake.

## Universal Turn Signal Installation

**NOTE:** If installing a steering column cover, do so before installing the turn signal.

1. Mount the turn signal assembly in a convenient location on the steering column using the included collars and hardware as shown. Once in place, carefully snap the hardware cover in place.

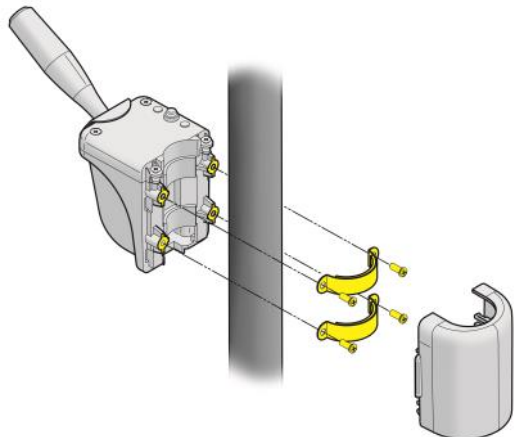

- Carefully route the turn signal harness down the left side of the steering column and behind the dash.

**NOTE:** The (2) control boxes can be removed if needed for routing purposes. Reinstall these once the harness is behind the dash compartment.

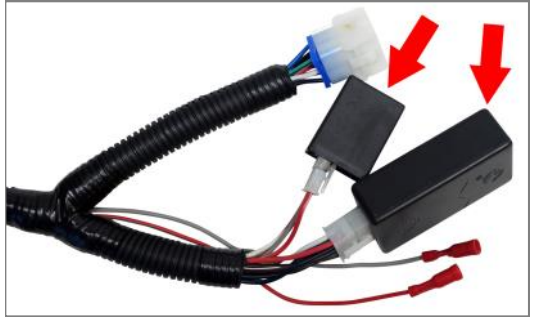

- Remove the jumper harness from the 9-pin turn signal connector on the RHOX plug and play harness.



- Connect the 9-pin connector on the turn signal to the 9-pin labeled "Connect to Turn Signal" on the plug & play harness.



- Connect the male bullet connector with the gray wire on the turn signal harness to the bullet connector on the plug & play harness to labeled "+12V Dimmer".
- If the head lights contain color accent lights, connect the female bullet connector with the red wire to the bullet connector labeled "Connect for Turn Signal Controlled Accent Lights".

**NOTE:** If the plug and play harness does not have a male bullet connector for the accent lights, connect this bullet connector to the T-harness included in this kit \*. The other end of the T-harness will connect in the same location as the optional toggle switch (refer to the light kit instruction booklet for toggle switch location).

\* T-harness may not be included in 2nd generation turn signal kits.

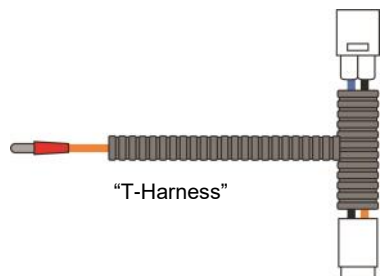

- Disconnect the push-pull switch from the plug and play harness as it will not be used with the T4. Replace it with the small jumper harness included in the kit.

**NOTE:** The T4 turn signal will control the ON/OFF function of the light kit.



- Adjust the turn signal switch wire cover to the appropriate length and snap it around the turn signal wire harness and steering column.
- Test the functionality of the turn signal.
- Secure any loose wires behind the dash.

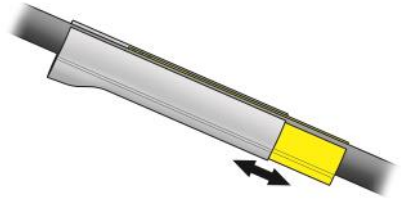

### LGT-T4 Turn Signal Features and Functions



## 12V Horn Installation

1. Connect the spade connectors on the horn harness (LGT-147) to the back of the horn on either terminal as shown below.
2. Mount the horn under the driver side front end of the vehicle in a location free of moving parts using the included hardware. Use a pre-drilled hole or drill a 1/4" hole in a safe location on the golf cart frame. The horn should face away from the cart and its passengers.
3. Connect the triangular plug on the horn harness to the triangular plug on the plug and play harness. Secure any loose wires with cable ties.

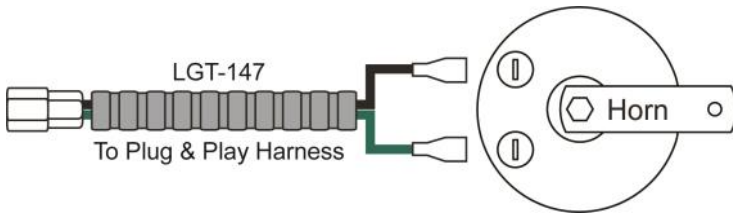
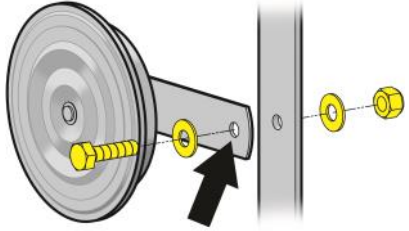

## Dual USB Outlet Installation

1. Find a convenient location on the dash or side compartments to mount the dual USB outlet.
2. Mark the center of the mounting location with a marking device.
3. Drill a 1-1/8" hole (maximum size) at the marked location.
4. Insert the outlet through the protective cap and into the mounting area. Secure it with the retaining nut.
5. Mount the flat panel cover (not required) over the outlet using the included screws.

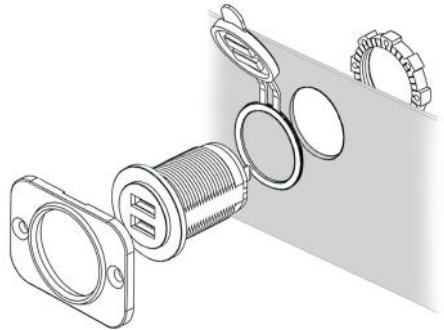

6. Connect the +/- 12V outlet leads on the light kit harness to the +/- 12V terminals on the back of the outlet.

**NOTE:** A fuse holder (ACC-0019) and 15A fuse (ACC-0021) are recommended if direct connecting the USB ports to a 12V battery or voltage reducer.

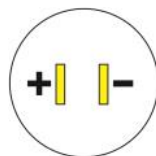

7. Secure any loose wires with cable ties.

### Universal Brake Pad Switch Installation (SOLD SEPARATELY)

1. Verify the cart is in the TOW position (if equipped), the key is OFF, and the wheels are chocked.
2. Lock the brake pedal and center the brake pad on the lower portion of the brake pedal assembly.
3. If mounting the switch using the included screws, fasten the pad directly to the brake pedal.

If mounting the switch using the included rivets, mark the hole locations and drill (6) 3/16" holes through the pedal. Mount the pad with the rivets

4. Run the wire under the brake pedal towards the brake connections on the plug and play harness. Route the wire so it is free and clear of any moving parts or pinch points..



5. Secure the brake pad wire to the bottom side of the assembly using cable ties. Slowly lower the pedal in PARK and recheck the wires. Readjust the cable ties if necessary.



**RUGGED  
STARTS  
HERE**

Your complete Plug and Play Turn Signal Kit is now fully installed.  
Please enjoy safely!